

The present work, produced by the [ECOSIGN Consortium](#), is licensed under a [Creative Commons Attribution-NonCommercial-NoDerivatives 4.0 International License](#).

# Ecodesign of electronic devices

## UNIT 10: Electrical power engineering

Author: Andrej Sarjaš

10.1. Electrical power engineering.....	2
10.2. Switch-mode functioning .....	4
10.3. Switch converter elements .....	11
10.4. Switch converters.....	19

Chapter summary:

- Power conversion principles
- Switching elements in power engineering
- Converters



## 10.1. Electrical power engineering

Electrical power engineering is part of electrical engineering that covers conversion and saving of electrical energy. All electronic appliances are powered by different sources. These sources can be autonomous and portable or stationary. Autonomous sources are all battery systems and devices that power portable and autonomous devices. Generally, battery systems are only a way of saving the energy that we supply from stationary systems, such as electrical network. Completely autonomous energy sources are systems that are not dependent on energy from electrical networks and do the conversion of non-electrical energy into electrical on the given spot. Such sources are different solar cells, wind power plants, etc.

On this spot, we can question ourselves what is conversion and electrical energy control? Energy is needed for all human efforts. Capacity and flexibility of modern electronics have to be accepted as new challenges for efficient use of energy. It is crucial to think how electronic circuits and systems can be used for conversion and energy management. Electrical power engineering includes studying of electronic circuits that are intended for control and electrical energy current. These circuits manage powers that are significantly higher than the price of each device. Rectifiers are probably the most known examples of circuits that fall under this definition. Converter is a term used for a certain type of circuits and systems that convert energy. Converters are classified depending on the type of input and output electrical energy. We know AC-DC, DC-DC, DC-AC converters and these are most often used as power supply units of electronic devices. As seen in image 1, electrical power engineering presents the middle point where energy systems, classical electronics, and power steering are joined. This is further supported by the fact that all microcontroller systems, digital logic circuits or simple steering for their functioning need electrical energy. This energy is generated from electrical power engineering that is the key domain of electrical power engineering. Each circuit for transmission and conversion of energy has to consider these issues from both perspectives, as control, and as energy conversion. The main topics of electrical power engineering are research on semiconductor elements, use of magnetic devices for energy saving, management methods that are part of modern energy systems. In each electrical engineering study, the importance of electronics has to be presented from the perspective of digital, analog and radio frequency electronics that reflect characteristic methods and unique challenges.

Applications of electrical power engineering spread exponentially. It is not possible to build computers, mobile phones, automobiles, airplanes, industrial processes and many other everyday products without electrical power engineering. Alternative energy systems, such as wind generators, solar energy, fuel cells and others all require electrical power engineering for their functioning. The technology advances, such as electric and hybrid vehicles, laptops, microwave ovens, flat panel displays, LED lighting and hundreds of other innovations that could not be executed until the advances in electrical power



engineering enabled their production. Although no one can predict future, it is clear that electrical power engineering will be in the center of core energy innovations.

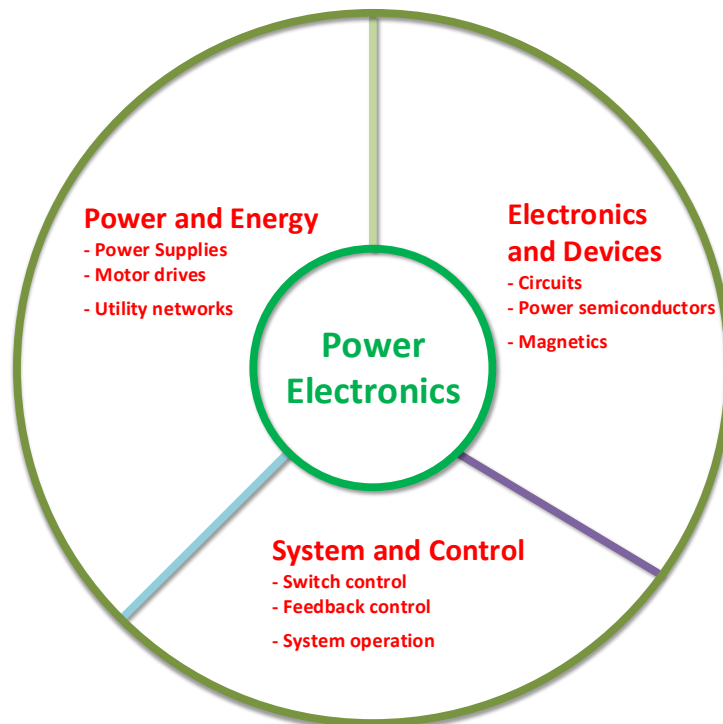

IMAGE 1: ELECTRICAL POWER ENGINEERING TOPICS

History of electrical power engineering is closely related to the improvements of electronic components that provide functioning with higher powers. Since 1990 the components and devices became so sophisticated that the transition from physical devices to program applications has begun. This transition was based on two key factors:

- For almost every application exist advanced semiconductors with suitable powers that are widely accessible.
- The main tendency for component miniaturization increases with the number of electrical devices and products.

Although devices are still improving, their development follows innovative applications and devices.

All electronic circuits regulate electrical energy current between electrical source and load. Components in circuit need to direct to electrical currents and not interfere with them. The general power conversion system is presented in image 2. The function of power converter, seen in the center of image 2, is control over energy current between source and load. In our case, the power conversion will be executed with the electronic circuit.



Because there is power converter between energy source and load, all used energy from the converter is distributed to all components inside the converter. Here is the key challenge. For building a converter, it is needed to use components without or with low losses. It is favorable that the converter efficiency is close to 100%.



IMAGE 2: ELECTRICAL ENERGY CONVERSION

A power converter that is connected to the source and load also influences the reliability of the system. If the energy source is completely reliable, the unreliable converter can influence the load. Unreliable converter is on load seen as an unreliable power source. The unreliable power converter also causes unreliability of the complete system. If we take a look at this from the perspective of the source, we can say that average European household experiences electrical network failure only a few minutes a year. Energy is available 99,9% of the time. Energy converter has to be reliable because only this can prevent system degradation. Ideal converter execution must not cause any problems in device's lifespan. High reliability can be a more difficult engineering challenge than the high efficiency of converter. From the perspective of the ecological design of electrical devices, the converters of energy are one of the foundations for reliable functioning and device efficiency. Converter efficiency influences device lifecycle that is an important methodology for evaluating the ecological efficiency of the device.

## 10.2. Switch-mode functioning

Functioning of switch converters is based on low-loss switches which are extreme requirements for electrical power engineering. In the ideal case, when the switch is on, it has a zero drop in voltage and will transmit full energy to the load without any additional losses. If the switch is off, it has unlimited resistance, meaning that no current will go through the switch. The power of switch is a product of voltage and current, meaning that the desired product of both values equals zero. If the power is equal to zero, we do not have any energy use on the switch element in the given time. The switch, therefore, regulates energy current without loss, where switch reliability is crucial. Household mechanical switches perform maybe even more than 100.000 switches in one decade of use. Unfortunately, the mechanical switches do not fit all practical needs. Electronic switches that are part of the power supply circuit switch even more than 100.000 times in one second. Even the best mechanical switches will not withstand more



than a million cycles. Due to this, we use semiconductor switches of selected powers in converters.

The concept of conversion system is presented in image 3. Conversion system consists of four separate units, which are:

- Energy source
- Converter's power circuit
- Unit for converter management
- Load

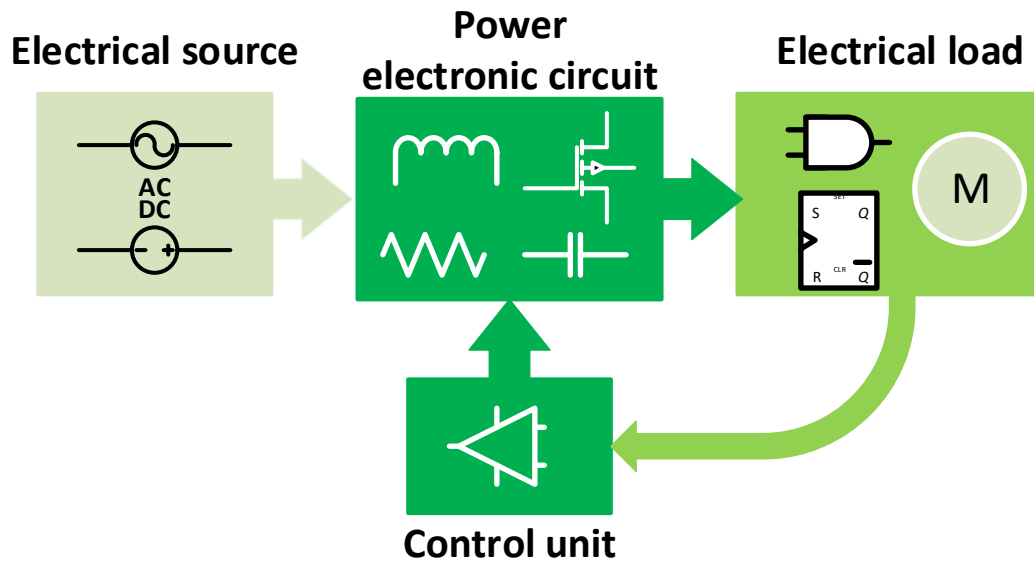

IMAGE 3: CONVERSION SYSTEMS

One of the energy sources in electronic device can be network voltage, battery or other alternative sources. Power circuits differ by the converter type which is differentiated depending on input and output voltage, as seen in image 4.

We know converters that convert alternating current into one-way (AC-DC - alternate current to direct current). AD-DC converter type is often used in electronic circuits that are powered by the electrical network and require a one-way current for functioning (logic circuits, one-way analog circuits, microcontrollers- computer systems, etc.). AC-DC converter is also known as a rectifier.

Another type are DC-DC converters (direct current to direct current). These are used for increasing or decreasing of one-way current. Electronic circuits and built-in elements for their functioning need different voltage potentials. With the use of DC-DC converters, we integrate voltage potentials in electronic circuits (the most common voltage potentials are 12V, 3.3V, 5V).



The last converter type are DC-AC converters (direct current to alternate current). These are also known as power inverters and are used for conversion of one-way to alternating current. They are often used in alternating electrical engines with adjustable speed and conversion of energy from alternative sources, such as solar power plant.

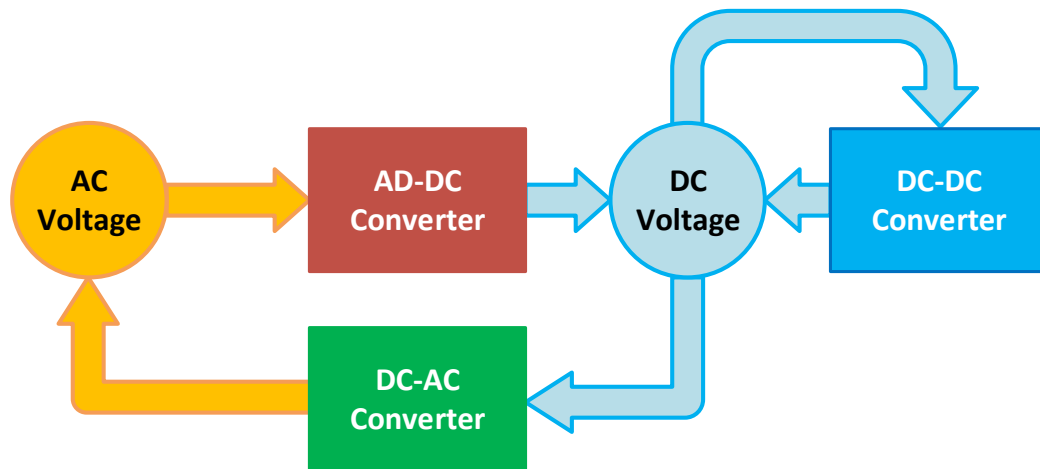

IMAGE 4: CONVERSION SYSTEM TYPES

Converter's control unit can be in the form of analog circuit or with a microcontroller. The control unit is responsible for control of semiconductor switches, depending on the desired converter output. This can be voltage level, phase shift or frequency of the periodic signal. Load type is conditioning the converter functioning and its control. For example, we know inductive or capacitive load that cause voltage or current edges and simple ohm loads that do not have a distinctive transitional appearance. We often see mixed loads that have resistance, inductiveness, but also capacitance. Known inductive loads are engines, relay and power contactors. All converter elements are designed in order to have as low energy losses as possible.

Switching devices are chosen by their capacities and desired energy transfer that is stated as a product of current and voltage. This is in opposition to other electronics applications at which we usually state power loss. For example, typical stereo receiver executes conversion of the alternating input voltage to audio output. Most audio amplifiers do not use electrical power engineering techniques where semiconductor components would serve as switches. The commercial 100W amplifier is generally designed with transistors that are big enough to transfer 100W of power. Semiconductor devices are used mainly for reconstruction of the audio signal, but not for manipulation of energy currents that cause significant losses. Amplifier for home theaters operates with efficiency below 10%. Contrary to these type of amplifiers, there are others that use electrical power engineering techniques for conversion of power. These techniques provide high efficiency. Home theater system that uses switching amplifiers can reach even 90% energy efficiency and have small dimensions. Often this type of amplifiers does not need additional cooling elements and are integrated into one chip. Amplifiers can even be built-in directly into speakers.



Switch converters can reach high power and are mechanically relatively small. Let us take a look at two examples:

Switch NTP30N20 is a metal-oxide transistor with allowed current 30A and voltage 200V. The maximum allowed dissipation power on switch is 200W with the suitable cooling system (cooling rib or fan) or 2,5W without cooling. In electrical power engineering theory, the rated power is  $30\text{ A} \times 200\text{ V} = 6\text{ kW}$  of energy from the source to the consumer. NTP30N20 operates in switching mode, meaning it is completely open or closed. Power dissipation is relatively low and mainly occurs in the switching time.

Many manufacturers use NTP30N20 for managing different household appliances, such as refrigerators, air conditioners, and other industrial tools. As previously mentioned, transferred energy through the switch is significantly higher than rated power level on the switch itself. The switch is suitable for transfer of energy up to 6kW and own energy of maximum 200W. The power ratio is 30:1, which is relatively high, but not unusual in the context of electrical power engineering. If we compare the given example of an audio amplifier that is not working in the switch mode, it needs to be guaranteed that the transferred energy is almost equal or even higher than the power of own transistor dissipation.

We can take a look at another example; IRGPS60B120KD is a bipolar transistor with isolated gates (IGBT- insulated-gate bipolar transistor) that was developed especially for electrical power engineering and operating in switching mode. Its rated values are 1200V and 120A. Its transferred power equals 144kW, which is sufficient for controlling an electrical or hybrid car. It is interesting to note that its own dissipation is only 500W, meaning its ratio to transferred power is 288:1.

Power applications bring us to interesting questions and challenges. In converters where the main part are low-loss semiconductor switches, they often manipulate with 30-fold dissipation power capacities. This means we only have approximately 3% loss. A small error in design can cause unexpected heat losses or a small change in element arrangement can drastically reduce converter efficiency. For example, if the loss is 4% instead of 3%, the voltage in the device is 33% higher, which consequently leads to device failure or error. Design of power converters can be summed with three main challenges:

- The first challenge is the reliability of power electronic circuits. We need to strictly comply with the nominal voltage, currents, and power delivered by the device. The power always has to be within limits. This is especially important when managing high powers.
- The second challenge is circuit simplicity. In electronic circuits, it is known that the more elements they contain, the higher the chance of error or failure of the complete system. Electrical power engineering circuits usually have many components, especially the main energy branches. For achieving converter efficiency, it is very important that we choose main





components reasonably. This means that sophisticated management strategies are implemented with simple electronic circuits.

- The third challenge is integration. One of the ways how to avoid compromise between reliability and complexity is the integration of larger components and functions into one substrate. For example, the microprocessor can contain millions of gates. All interconnections and signals are running inside on the chip, and the reliability is dependent on only one component. An important trend in electrical power engineering is development of integrated modules. The manufacturers are searching for ways how to integrate as many important components into one module as possible. Miniaturization of components also creates new challenges. Many semiconductor elements contain small binding wires that can be sensitive to heat or vibration damages. Smaller geometries can also increase electromagnetic disturbances between internal components.

Two main trends are accelerating the electrical power engineering development. One the one hand, we have a high capacity microprocessor, memory chips and other advanced digital circuits that increase converter capacities at very low voltage. Here we can highlight power supply of powerful processors, where current requirements are 100A at only 1V. In such systems, we also have variable load and time requirements in micro or nanoseconds. Contrary, we have many portable devices that are powered by different types of rechargeable batteries. Power supplies for these devices have to be efficient and low-cost. Currently, power supplies and chargers in these devices have relatively high losses and low efficiency. Due to this, today's requirements and efforts are oriented towards efficiency improvements and lower energy consumption. Efficiency standards, such as program EnergyStar, set rigorous requirements for a wide spectrum of low-voltage power supplies.

In the past, linear power suppliers were made with transformers and rectifiers that converted AC voltage to DC. In the late 1960s, the use of one-way sources in airline and space industry led to the development of switching power engineering converters. In a well-designed switch converter, the alternating voltage source from the network is rectified without direct transformation, as in linear converters. The given one-way high voltage is a converter with a DC-DC converter to the prescribed voltage level. The personal computer often requires several power supply levels (3.3V, 5V, 12V) and 1V for the processor. Only switch converters can provide several voltage levels.

A very interesting is a comparison of analog and switch converters. Switch converters are seen as devices with high efficiency, smaller dimensions and high power in comparison to linear converters. They also do not need a complex cooling system. But these devices are more complex than linear and cause corrugated output voltage, which prevents the use of certain precise applications. Linear converters are nowadays most often used for lower powers





as stabilizers of different electronic components. Here are some characteristics of both groups.

- **Linear DC power supplies:** Were widely used until the late 1970s. With technology advancement of switching power supplies, the linear power supplies are nowadays less popular but still used in applications that require non-corrugated and stable output voltage. Linear power supplies use a large transformer for the transformation of high AC voltage to low AC voltage. Next steps after transformation are rectifier circuits and different filters that create low-wave DC voltage. Low one-way voltage is then regulated to the given level with voltage stabilizers. The typical applications of linear power supply systems are:
  - a) Audio technology, studio mixers.
  - b) Low-noise amplifiers.
  - c) Signal processing.
  - d) Data gathering with ADC converters.
  - e) Closed-loop management.
  - f) Precise laboratory equipment.
  
- **Switching DC power supplies:** These were first introduced in the late 1970s and nowadays the most popular type of DC power supplies on the market due to exceptional energy efficiency. Switch rectifier adjusts output voltage with pulse width modulation PWM. The PWM technique creates high-frequency disturbances but enables that electrical voltage is produced with very high power efficiency. With a good design, the switching voltage has great disturbances regulation and line load. The typical applications for switch DC power supplies are:
  - a) High-voltage and current applications.
  - b) Mobile and communication devices.
  - c) Battery charging for different devices and vehicles.
  - d) One-way motors.

Image 5 presents 5V DC-DC linear voltage converter.



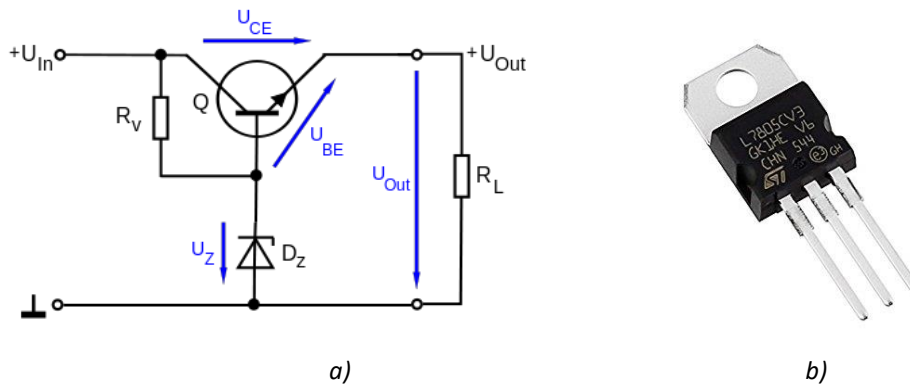

IMAGE 5: A) LINEAR VOLTAGE CONVERTER SCHEME, B) PRODUCING 5V CONVERTER IN TO-220 HOUSING.

As seen in image 5, Zener diode stabilizes output voltage, meaning the voltage surplus is spent on resistance  $R_v$ .

This is the main reason for converter overheating that often needs appropriate cooling for reliable functioning at higher currents and higher input voltage. For example, if we want to stabilize power supply 5V at battery supply 12V, the voltage difference 7V will be spent on resistance  $R_v$ . The wiring diagram of the voltage regulator is presented in image 6.

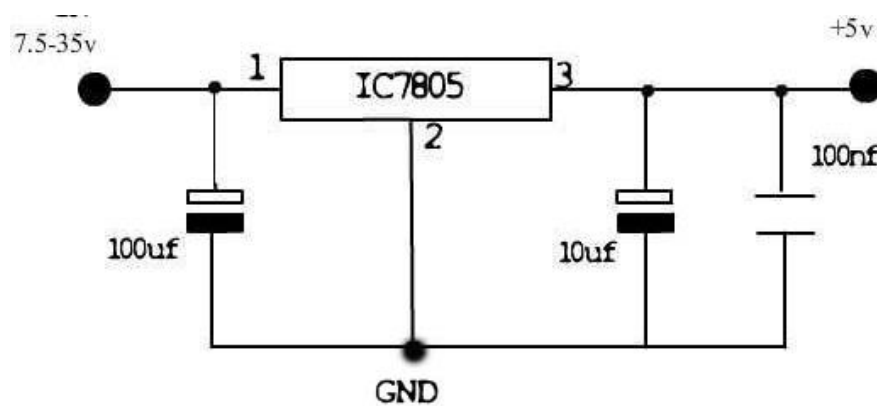

IMAGE 6: WIRING DIAGRAM OF THE VOLTAGE REGULATOR.

Image 7 presents switching DC-DC converter.



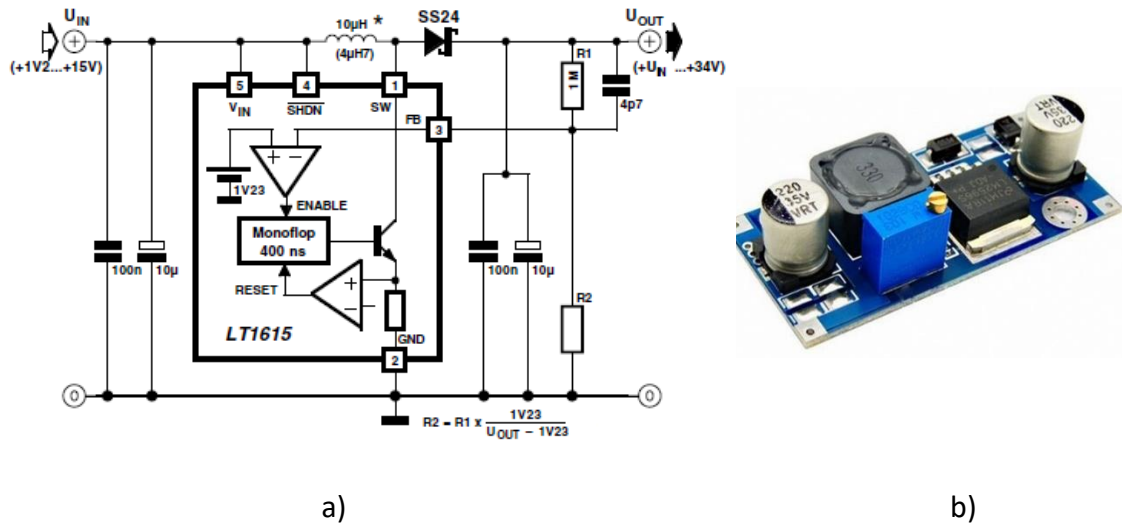

IMAGE 7: A) SWITCHING DC-DC CONVERTER SCHEME, B) PHYSICAL APPEARANCE OF DC-DC CONVERTER.

### 10.3. Switch converter elements

Electronic switches that are capable of managing high voltages and currents in high-frequency range are the most important elements in designing systems for energy conversion. So, which switch is ideal? Ideal electronic switch can be a device with three connectors, as seen in image 8.

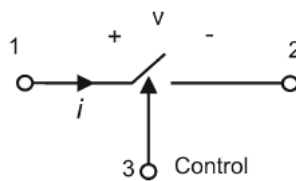

IMAGE 8: IDEAL SWITCH.

We can see input, output and control clamp. The control connector controls the switch in modes open/closed (ON/OFF). Ideal switch means that in the open mode there is no resistance and in the closed mode there is infinite resistance. This switch changes the condition instantly, so the needed time to switch from ON to OFF or OFF to ON is zero. Actual switches have limitations in all characteristics that have been mentioned at the ideal switch. For example, when the switch is on, we have a drop of voltage, meaning it has a certain resistance. When switched off, some current can be leaked, meaning it does not have infinite resistance. The switch time is also not infinitely fast. As a consequence of given non-ideal switch characteristics, voltage and current are always present in the switch, and consequently, there are two types of losses. The first type of losses occurs between modes ON and OFF and are known as switching losses. The



second type are consequences of own resistance of the switch that occur during opening or closing. These losses are transfer and leaking losses.

The concept of the ideal switch is important for circuit evaluation. Assumptions on zero voltage drop, current leak and switching occurrences ease simulation and modeling on different converter switch behavior. Depending on characteristics of the ideal switch are three classes of power switches:

**Uncontrolled switch:** The switch does not have control connector. Switch mode is determined by an external voltage or current circuit conditions in which the switch is in. An example of such switch is a diode.

**Half-controlled switch:** In this case, the circuit designer has limited control over the switch. For example, the switch can be turned on with control connector, but when it is closed, it cannot be unlocked with the control signal. The switch can be turned off depending on current circuit state or with added control electronics that forces the switch to turn off. An example of this switch is thyristor.

**Fully controlled switch:** The switch can be turned on or off through control connector. Examples of this switch are bipolar transistor BJT, MOSFET transistor, and IGBT transistor.

### 10.3.1 Uncontrolled switch

Diode is also known as a rectifier and is an uncontrolled switch. It is an element with two connectors, seen in image 9. The connectors are anode (A) and cathode (K). In the ideal case, diode current ( $i_d$ ) is one-way, meaning current is only going from anode to cathode.

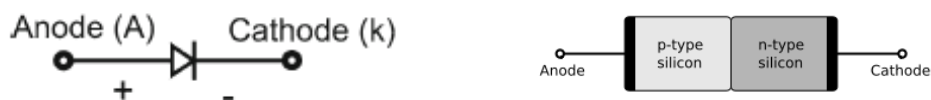

IMAGE 9: SYMBOL OF SEMICONDUCTOR DIODE AND SEMICONDUCTOR STRUCTURE.

Diode voltage  $V_d$  is measured as the voltage between anode and cathode. U-I diode characteristics are presented in image 10. In the first quadrant, the diode is in open mode, meaning it is conducting. On diode, we have a small drop of voltage that is dependent on semiconductor type that is used in the diode. Voltage drop on silicon diode is 0.7V and in germanium diode approximately 0.3V. Diode current is exponentially changing with diode voltage. In the third quadrant, diode is closed, meaning there is no minimal current or current leakage. The ideal diode characteristics are shown in image 10 b).



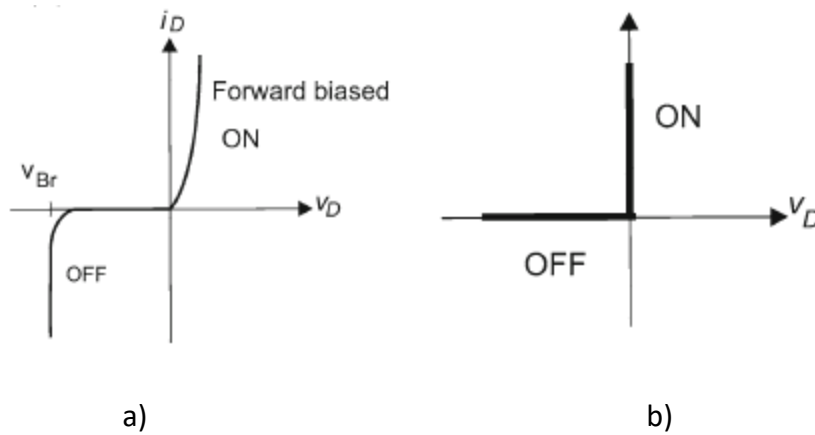

IMAGE 10: U-I CHARACTERISTIC OF DIODE: A) REAL, B) IDEAL.

### 10.3.2 Half-controlled switch

Thyristor or SCR is semiconductor switch which can be opened with control clamp gate. When the switch is on, it cannot be turned off through control clamp and thyristor works similar as a diode. This means thyristor is classified as a half-controlled switch. Image 11 presents a symbol of thyristor. Even though there are certain similarities between thyristor and diode, thyristor is working differently. Thyristor current is running from the anode to cathode, and thyristor voltage  $U_{AK}$  is positive, which is presented in U-I characteristic in image 12 a).

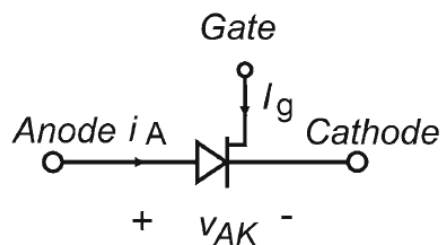

IMAGE 11: THYRISTOR SYMBOL.

In quadrant one is visible that the control connector of thyristor does not conduct without current. In case current goes through control connector, thyristor starts conducting and has a very similar characteristic as an ordinary diode. In quadrant three, thyristor does not conduct, meaning it is closed. Thyristor here has a similar characteristic as a diode. Although thyristor characteristic is similar, we can see at switch characteristics that thyristor transfers higher voltage when closed. High closed voltage is important for different power systems, such as AC-AC converters.



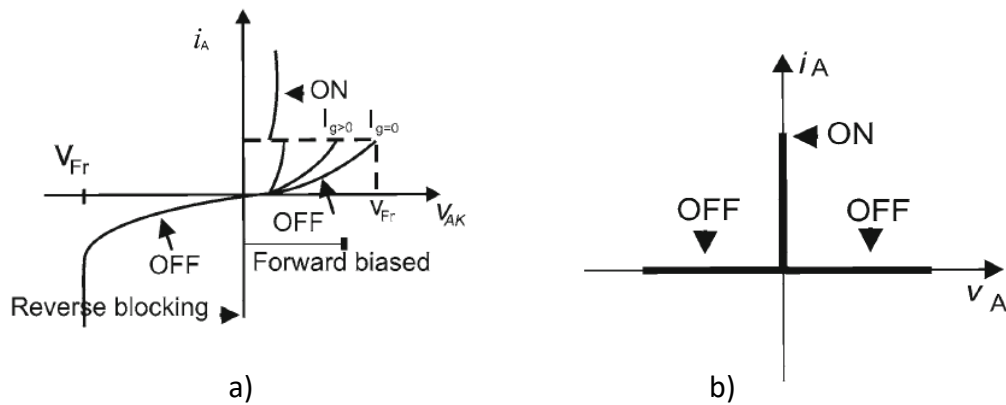

IMAGE 12: U-I CHARACTERISTIC OF THYRISTOR: A) REAL, B) IDEAL.

From characteristic of the thyristor in image 12 we can see that current only goes in one direction. We also know a similar element that is also a semiconductor switch, with the difference that the current goes in both directions. This element is triac, seen in image 13. It consists of two thyristors that are connected in reverse direction. U-I characteristic of triac is presented in image 14. With control connector, we can control symmetrical switching in positive and negative half-period of the input signal. Triac is mainly used for transferring lower powers, such as control of single-phase motor, dimming system, etc.

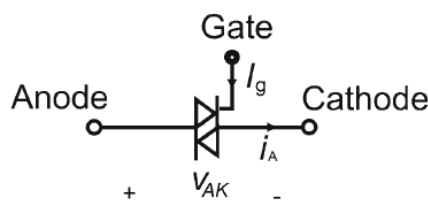

IMAGE 13: TRIAC SYMBOL.

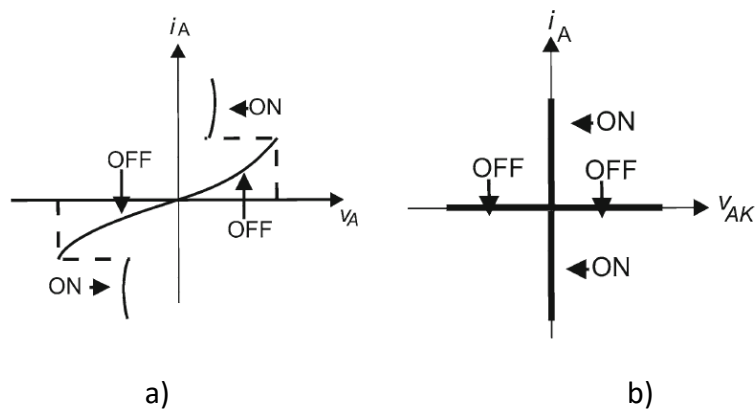

IMAGE 14: U-I CHARACTERISTICS OF TRIAC: A) REAL, B) IDEAL.



### 10.3.3 Fully controlled switches

In fully controlled switches, the modes open/closed can be activated through control connector. The short description of each device is given in the following points.

**Bipolar transistor**–BJT (bipolar junction transistor) is a fully controlled switch, where we use base (B) to open the switch, as seen in image 14 a). In NPN transistor, we use positive base voltage to open the transistor. The current in it goes from the collector (C) to emitter (E) and in the reverse direction, the transistor is non-conductive. In PNP type, transistor openness is controlled with negative base voltage where current is going from emitter to collector.

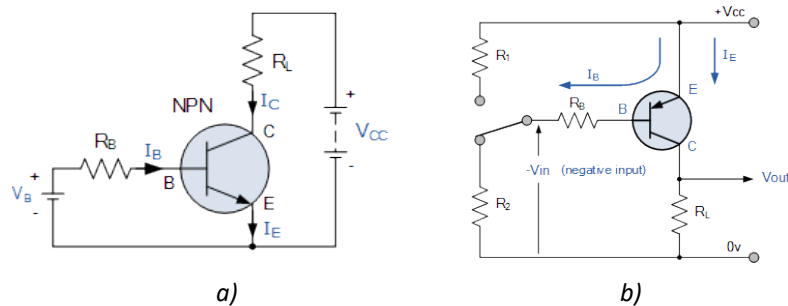

IMAGE 14: TRANSISTOR SYMBOL: A) NPN TYPE, B) PNP TYPE.

The internal transistor structure is presented in image 15.

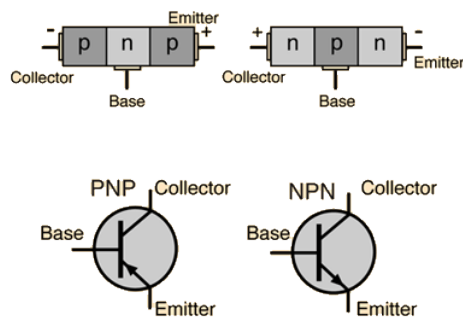

IMAGE 15: TRANSISTOR STRUCTURE.

From static characteristic of NPN transistor in image 16 a) is visible that element has three fields of operation. In two works as a switch and in the third works as a linear amplifier. The switch is closed when the value of base current  $I_B=0$  and open when the voltage between the collector and emitter  $V_{CE}$  is smaller than  $V_{CEsat}$ . If we look at ideal characteristic in image 15 b), it means that in open mode the transistor between C and E leaks current  $I_C>0$  at  $V_{CE}=0$ . For transfer of high powers, IGBT transistor is generally used instead of the transistor.





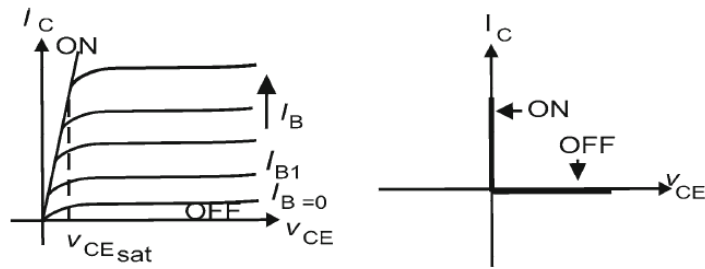

IMAGE 16: STATIC CHARACTERISTIC OF TRANSISTOR: A) REAL, B) IDEAL.

**MOSFET transistor.** MOSFET (metal oxide semiconductor field effect transistor) has been named after operating principle, as seen in image 17. Similarly as a transistor, it has three connectors (G),(D) and (S).

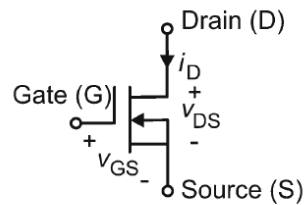

IMAGE 17: MOSFET TRANSISTOR SYMBOL.

Channel openness is controlled through a connector (G), which uses electric field between the reverse polarized substrate for its functioning. The electric field can be managed with voltage  $V_{GS}$ , which causes channel openness between the connector (D) and (S). Due to a thin layer of silicon dioxide  $SiO_2$  between channel and gates, it has high input resistance. Due to this and very low resistance  $R_{DS}$  during conducting, it is a suitable element for electrical power engineering and switching operation. Opening conducting channel with electric field enables transfer of high currents. It is also important to note that bipolar transistor is a current-controlled element with current  $I_B$ . MOSFET transistors are voltage-controlled elements with voltage  $V_{GD}$ . Static characteristic MOSFET is very similar to a bipolar transistor, as seen in image 18.

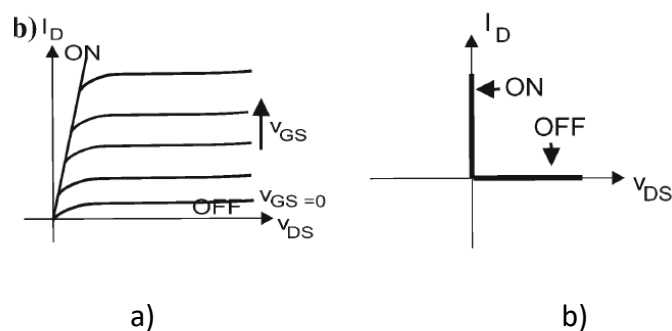

IMAGE 18: STATIC CHARACTERISTIC OF MOSFET: A) REAL, B) IDEAL.

Below is presented structure of MOSFET transistor.

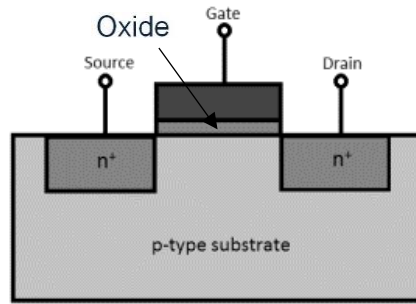

IMAGE 19: MOSFET TRANSISTOR STRUCTURE.

If we compare images 15 and 16, we can see that the structure of MOSFET is significantly different than BJT transistor. In MOSFET we create conducting channel by supplying voltage  $V_{GD}$  between (G) and (D). The voltage  $V_{GD}$  creates an electric field that creates conducting  $n^+$  channel between two built-in  $n^+$  substrates inside p substrate. The higher the voltage, the wider the channel, meaning the channel resistance is lower. In static functioning, we use modes fully open or closed.

The disadvantage of MOSFET is great voltage sensitivity on input gates (G), which is a result of great input resistance. Due to this, it is important to beware the voltage size  $V_{GD}$ . Some MOSFET have built-in safety diodes for this reason. The MOSFET disadvantage is also relatively high capacity, which limits use at high frequencies. For this reason, there have been other versions that use two (G) connectors. This way, we mechanically reduce compound surface. The good characteristics of MOSFET are very small dimensions for great powers, high switching speed, resistant to thermal loads. Table 1 presents the difference between bipolar and MOSFET transistor.

<b>Property</b>	<b>BJT</b>	<b>MOSFET</b>
<b>Input resistance</b>	low	high
<b>Control</b>	Current (need power)	Voltage (no power)
<b>Switching 'ON' time</b>	50-500ns	5-500ns
<b>Switching 'OFF' time</b>	400-2400ns	5-500ns
<b>Frequency</b>	80MHz	1.5GHz
<b>Conduction resistance</b>	0.3Ω	0.01-1Ω
<b>Overload sensitivity</b>	bad	good
<b>Thermal stability</b>	Need	No need

TABLE 1: COMPARISON BETWEEN BIPOLAR AND MOSFET TRANSISTOR.



IGBT transistor is hybrid between BJT and MOSFET transistor. IGBT contains good characteristics of MOSFET, such as fast switching and low conducting resistance of BJT transistor. IGBT is Darlington connection, made of MOSFET and BJT transistor, as seen in image 20 a). MOSFET controls base current in BJT transistor.

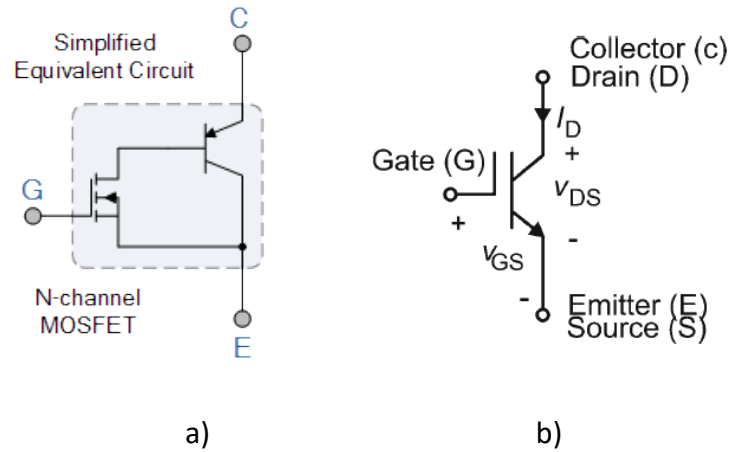

IMAGE 20: IGBT TRANSISTOR.

Symbol of IGBT transistor consists of MOSFET and BJT transistor. Control connector (G) and conducting channel (marked with (C) and (D)) can be seen in image 20 b). Static characteristic is presented in image 21.

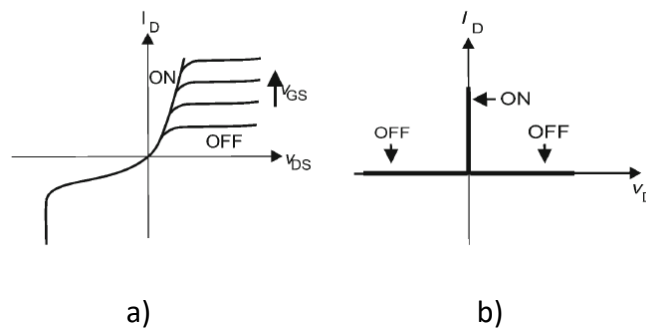

IMAGE 21: STATIC CHARACTERISTIC OF IGBT TRANSISTOR: A) REAL, B) IDEAL.

IGBT transistor is suitable for switching at higher powers. In comparison to MOSFET, the control voltage  $V_{GS}$  is somewhat higher, but current capacities are significantly higher as in MOSFET. Table 2 presents a comparison between power transistors.



Property	BJT	MOSFET	IGBT
Voltage rating	High <1kV	High <1kV	Very High >1kV
Current rating	High <500A	Low <200A	High >500A
Input drive	$h_{FE}$ 20-200	3-10V	4-8V
Input impedance	Low	High	High
Output impedance	Low	Medium	Low
Switching speed	Slow	Fast	Medium
Cost	Low	Medium	High

TABLE 2: COMPARISON OF BJT, MOSFET AND IGBT TRANSISTORS.

From data above, we can see that BJT transistor is rarely used for power converters because the power is easy to substitute by MOSFET transistor. At very high currents and voltage, it is only possible to use IGBT transistor.

## 10.4. Switch converters

In this chapter, we will only present switch converters. These provide high efficiency and are, therefore, from the ecodesign perspective suitable to be built into most modern electronic devices.

### 10.4.1 AC-DC switch converters – rectifiers

AC-DC converters are power circuits that convert alternating voltage into one-way. AD-DC converters are part of most electronic devices. The reason for this are their efficiency and yield that are both very important. There are several principles and other approaches to AC-DC converters. The advantage of switch AC-DC rectifier in comparison to the ordinary one is higher efficiency and smaller dimensions with the same powers. For ecodesign purposes, we will present the principle for switching converter that is widely used due to high yield in different electronic devices, such as television receivers, personal computers, audio devices, etc. Image 22 presents switch rectifier scheme.

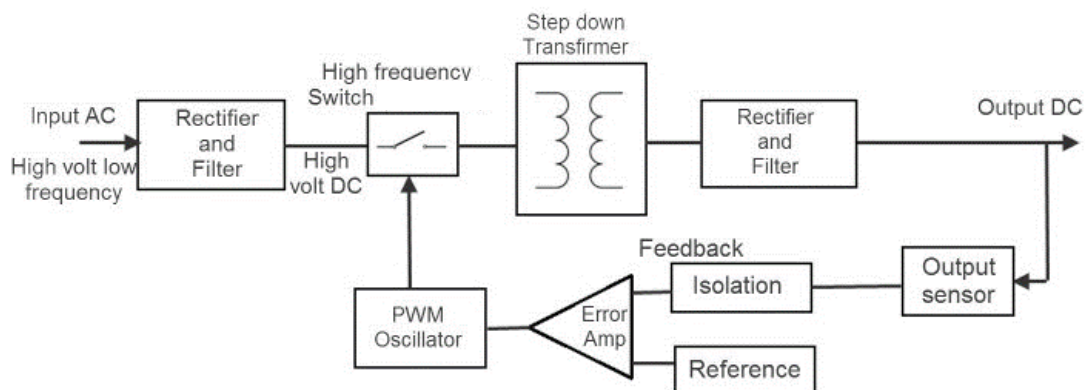
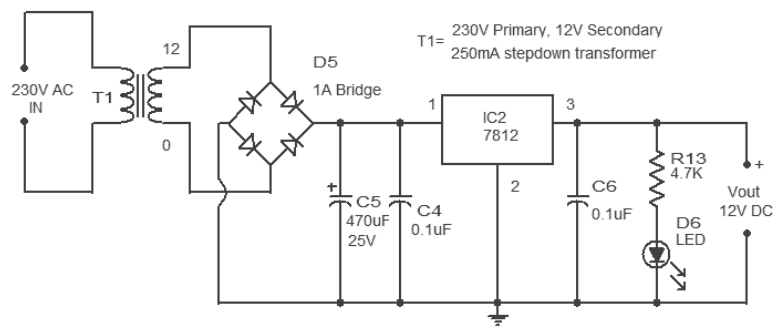

IMAGE 22: AC-DC SWITCH CONVERTER.



Switch AC-DC converter in the first block instantly directs alternating input voltage with half-wave or full-wave diode rectifier. Many AC-DC converters in the first phase contain different filters for removing noise and edges from the network. In the second phase, the voltage is brought through high-frequency switch which is controlled depending on the desired output voltage. Switch frequency is usually between 10 to 100kHz, depending on the converter type. From the switch, we get a pulse train that has the same frequency as the switch. The pulse train is brought to the transformer, where the voltage is lowered. Used transformer contains fewer layers on primary and secondary level, which drastically reduces the transformer size and quantity of used materials. On transformer output, we can use a low permeable filter for smoothing voltage or DC-DC switch converter. Depending on the desired output one-way voltage, we control the switching speed.

Image 23 presents classical AC-DC converter with input transformer. Transformer dimension is dependent on power and alternating voltage transformation ratio. In comparison to the transformer in switch AC-DC converter, dimension ratio can be even 1:10 in favor of switch AC-DC converter.



**IMAGE 23: CLASSICAL AC-DC CONVERTER**

#### 10.4.2 DC-DC switch converters

DC-DC converters are used for supplying one-way consumers that can be found in many electronic devices. Converters provide regulation of one-way voltage on certain consumers. They are also used for Galvanic separation of a certain circuit. We know four types of DC-DC converters:

- **Step-down converter (buck converter)**
- **Step-up converter (boost converter)**
- **Step-down and step-up converter (Buck-Boost converter)**
- **Ćuk converter**

**Converter step-down**, as the name suggests, lowers DC input voltage. Step-down converter scheme is presented in image 24.



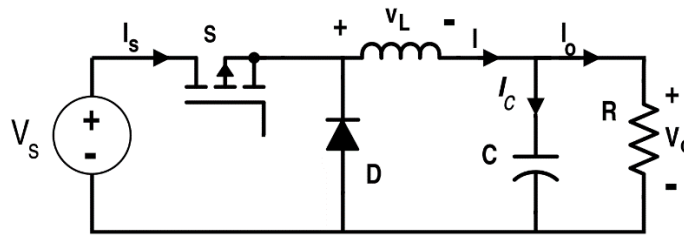

IMAGE 24: STEP-DOWN CONVERTER.

Operating principle of the converter is simple; we control the switch by leading input voltage to LC circuit. When the switch is closed, the current is going to LC circuit and powers the load. In case the switch is not closed, diode itself closes secondary circuit that is the consequence of own induction in the coil. The switch is usually controlled by PWM signal. LC circuit is a low-frequency sieve that smooths corrugations of the output voltage due to the switching. For controlled switch depending on the power, we can use BJT, MOSFET or IGBT transistor. Depending if the switch is open or closed, we get an average value at converter output that is lower than  $V_{IN}$ . With suitable design and element choice, we can design highly efficient and reliable DC-DC converter. Many manufacturers offer DC-DC converter in an integrated circuit. Integrated form means that key converter elements are all on one chip. Depending on own needs, we need to choose coil, reference output voltage, and capacitor.

**Step-up converter** is used for one-way consumers that need a higher voltage than is connected. Step-up converter scheme is presented in image 25.

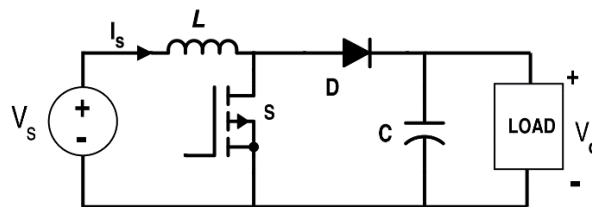

IMAGE 25: STEP-UP CONVERTER.

The operating principle is based on own induction of the input coil. With fast switching, the switches cause voltage edges in coil L. In case the switch is concluded, the current is going through the coil back into the power supply. In this phase, we cause coil's own induction, meaning we save energy in L. When the switch is not closed due to own induction, the coil redirects saved energy through the diode into a capacitor that acts as energy storage in secondary circle and smoothener of the output voltage. Size of voltage edges depends on switching speed. The faster the switch, the higher voltage edge is in coil L. In this case, we also control the switch with PWM signal where switching



speed is controlled by output voltage. Step-up converter can be found in integrated form, similarly as a step-down converter.

**Step-down/up converter.** Depending on the common connector in an electronic circuit, there often appears a need for negative voltage on converter output. For this cases, step-down/up is used, seen in image 26.

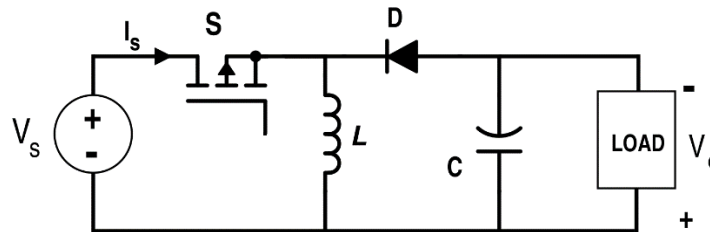

IMAGE 26: STEP-DOWN/UP CONVERTER.

Step-down/up converter consists of cascade converter step-down and step-up. The presented scheme shows realization of both converters with half-set of elements. The converter can generate lower or higher voltage depending on connected potential. The operating principles are following: when the switch is closed, the current goes through the coil L. When the switch is open due to own induction of coil L and negatively polarized diode, the current goes in the reverse direction. On capacitor C we get negative voltage, depending on connected voltage. The ratio between output and input voltage is given with duty cycle of PWM signal ( $V_o/V_s = D(1/(1-D))$ ). PWM signal can have in the given example +. This can have value between 0 and 1 (0-100%).

**Ćuk converter** was named after Slobodan Ćuk, who has been the first to develop such circuit, as seen in image 27. Ćuk converter is basically step-down/up converter that can generate a negative voltage in output. The main difference is that capacitor and not coil is responsible for energy transfer, in comparison to previous examples. For Ćuk converter it is typical that the energy is being transmitted in both switch modes (ON and OFF). In classical converter, the energy is only transmitted when the switch is in one state open or closed.

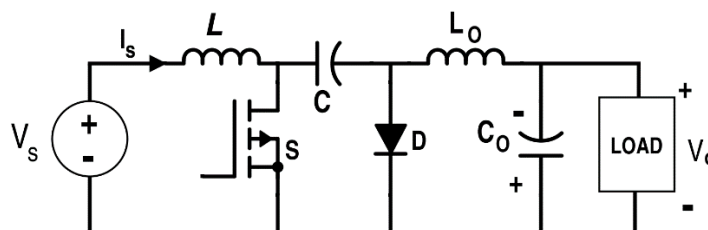

IMAGE 27: ĆUK CONVERTER.





### 10.4.3 DC-AC switch converters – inverters

DC-AC converters are electrical power engineering circuits that convert the output of the one-way voltage source, such as batteries, solar cells or fuel cells into alternating AC voltage. Inverters are often used for propulsion of electrical motors or voltage generators. Inverters are key in systems of uninterruptible power supplies system UPS. Inverters can often be classified depending on their output power and number of phases (single or three-phase) and depending on conversion type (half-wave or full-wave). In DC-AC converters, we know many types and modes of conversion, so we will only present single phase converter with a bridge circuit, seen in image 28.

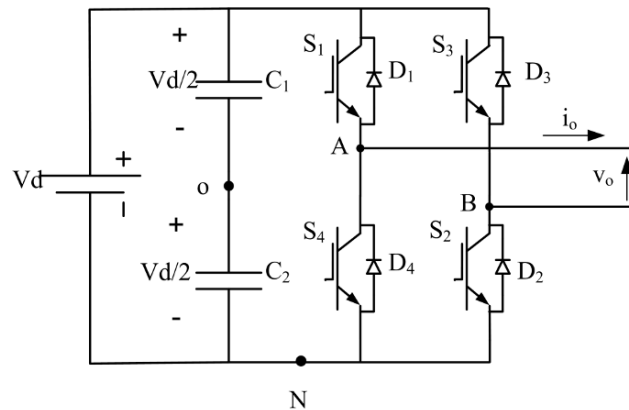

**IMAGE 28: SINGLE PHASE BRIDGE CIRCUIT INVERTER CIRCUIT.**

The operating principle of the circuit is based on electronic control of switches  $S_1$ - $S_4$ . The switches are switched diagonally  $S_1S_2$  and  $S_3S_4$ , where we need to be careful not to close  $S_1S_4$  or  $S_3S_2$ . With this change, we can cause a change of direction of output current  $i_o$ . For switch control is used PWM modulation, with which we can get relatively smooth alternating voltage.

